

DBF 4XLT

Dryer Exhaust Booster

STANDARD FEATURES

- Airtight galvanized steel housing
- Permanently lubricated sealed ball bearings
- Self-cleaning backward curved impeller
- Automatic reset thermal overload protection
- 5 1/2 foot 120Vac power cord
- Five-year factory warranty

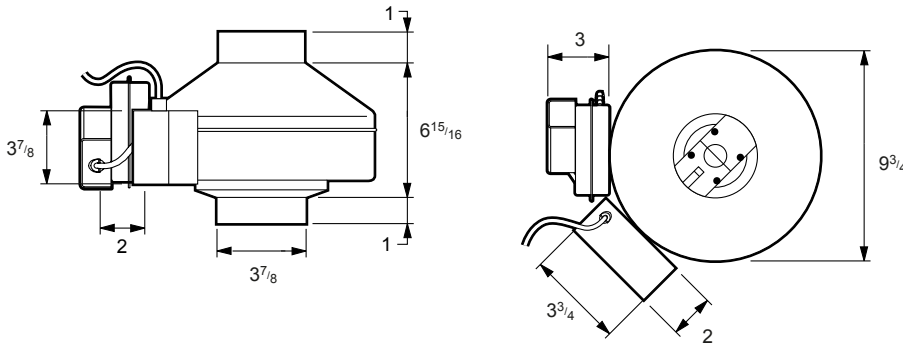

Model	Metal Gauge	Weight
DBF 4XLT	22	10

All dimensions in inches. Weights in pounds.

Fan Specifications							Motor Specifications					
Line	Qty	Model No.	Tag	CFM	SP	Fan RPM	Watts	Volts	Phase	Hertz	Encl	
1												
2												
3												
4												

Accessory Items	1	2	3	4	Accessory Items	1	2	3	4

Project: _____ Submitted: _____
 Customer: _____ Approved: _____
 Location: _____

United States 10048 Industrial Blvd. • Lenexa, KS 66215 • 1.800.747.1762 • www.fantech.net
Canada 50 Kanalfakt Way • Bouctouche, NB E4S 3M5 • 1.800.565.3548 • www.fantech.net

Fantech reserves the right to make technical changes.
 For updated documentation please refer to www.fantech.net

